



INTERNATIONAL APPLICATION PUBLISHED UNDER THE PATENT COOPERATION TREATY (PCT)

<p>(51) International Patent Classification ⁶ : D01G 25/00, D04H 1/72 // D21H 27/00</p>	<p>A1</p>	<p>(11) International Publication Number: WO 96/10663 (43) International Publication Date: 11 April 1996 (11.04.96)</p>
<p>(21) International Application Number: PCT/DK95/00359 (22) International Filing Date: 7 September 1995 (07.09.95) (30) Priority Data: 1132/94 30 September 1994 (30.09.94) DK (71) Applicant (for all designated States except US): NIRO SEPARATION A/S [DK/DK]; Vejlevej 3-5, DK-8700 Horsens (DK). (72) Inventor; and (75) Inventor/Applicant (for US only): SØRENSEN, Birger, Elgård [DK/DK]; Viemosevej 3, DK-7120 Vejle Ø (DK). (74) Agent: HOLME, Edvard; Holme Patent A/S, Sankt Peders Stræde 41, DK-1453 Copenhagen K (DK).</p>	<p>(81) Designated States: AM, AT, AU, BB, BG, BR, BY, CA, CH, CN, CZ, DE, DK, EE, ES, FI, GB, GE, HU, JP, KE, KG, KP, KR, KZ, LK, LR, LT, LU, LV, MD, MG, MN, MW, MX, NO, NZ, PL, PT, RO, RU, SD, SE, SI, SK, TJ, TT, UA, US, UZ, VN, European patent (AT, BE, CH, DE, DK, ES, FR, GB, GR, IE, IT, LU, MC, NL, PT, SE), OAPI patent (BF, BJ, CF, CG, CI, CM, GA, GN, ML, MR, NE, SN, TD, TG), ARIPO patent (KE, MW, SD, SZ, UG).</p> <p>Published With international search report. In English translation (filed in Danish).</p>	

(54) Title: A PLANT AND A PROCESS FOR DRY-PRODUCING A WEB-FORMED PRODUCT

(57) Abstract

A plant for producing, under dry conditions, a web-formed product by compounding different materials, including fibres, is disclosed. The plant comprises an endless, during operation mainly horizontally running perforated forming belt (2), a beneath the belt placed suction unit (3), and at least one above the belt placed material distributor (1) with a housing (13) having side walls (14) and a top wall (15). The housing is divided in the vertically direction into distribution steps (4, 5, 6) each with a separate perforated base (16, 17, 18) and each with a set of rotors (19, 20, 21) with wings (32) for distribution of the materials over the base. The distribution steps are each equipped with independent material inlets (7, 8, 9) for materials of different size and different density. Each material inlet feeds the respective step with material having a greater rate of fall, in air, than the material which is feeded from the material inlet of the underlying step. The web-formed product thereby can be produced with a more even and uniform structure and at the same time greater relative strength than known before. The plant is particularly suited for the production of, by way of exemple, nappies, sanitary towels, incontinence pads with a content of a super absorbent agent in form of e.g. a powder, cellulose fibres and long thermo-binding fibres.

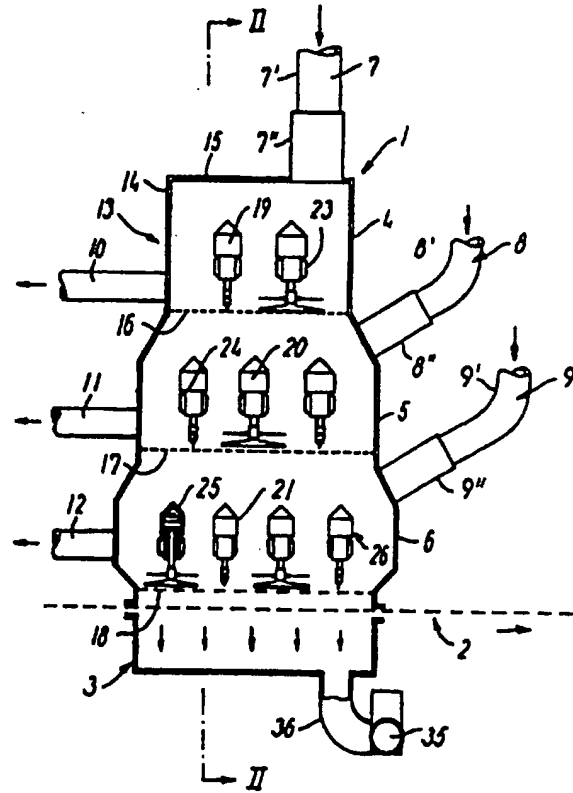

A PLANT AND A PROCESS FOR DRY-PRODUCING A WEB-FORMED PRODUCT

The invention concerns a plant for producing, under dry conditions, a web formed product by compounding different materials, including fibres, whereby the plant comprises
5 an endless, during operation mainly horizontal running perforated forming belt, a beneath the belt placed suction unit, and at least one above the belt placed material distributor with a housing having side walls and a lower perforated base, material inlets for the
10 different materials in the compound, and a set of rotors with wings rotating during operation to mix the materials and distribute these over the base.

The dry-forming process carried out by means of the above
15 mentioned plant, is particularly suitable for the production of a large number of different products, of which kitchen towels, toilet paper, paper towels, serviettes, nappies, sanitary towels and incontinence pads can be mentioned. The process has, in comparison
20 with a similar wet-forming process, amongst other things the advantage, that a super absorbent agent can be added to the products in the form of for example a powder (SAP) or fibres (SAF) during the production, and this is, of course, not possible when the process itself is wet.

25

When the dry-formed product contains such a super absorbent agent, it will be able to quickly absorb very large amounts of liquid in the form of e.g. urine or menstruation blood. This property is valued highly by the
30 consumers, who incidentally also wants a product, which is as thin and strong as possible.

In order to get a super absorbent agent, as e.g. SAP, to work at its optimum, it must be distributed evenly and
35 uniformly in the product. The property of great strength also demands that the other ingredients, which forms part

of the product, and not at least the different fibres, are mixed thoroughly.

Danish patent application no. 0265/93 disclose a plant
5 which produces a web formed product by means of a dry forming process, which even with the addition of a powder as SAP can be given quite an even and uniform structure, provided, however, the fibres are not much too long.

10 SAP consists of comparatively small and heavy particles, which have a tendency to easily and quickly pass through the holes in the base, which therefore must be quite small in order to force the particles to remain for a time so long above the perforated base that the particles
15 can attain to be distributed over the entire area of the base and be mixed thoroughly with the other materials.

The fibres are lighter than the SAP particles and have, at least in the longitudinal direction, a greater
20 extension. The fibres therefore can not be brought to pass through the holes in the base concurrently with the SAP particles without being damaged or destroyed, when the holes in the base are specifically adapted to control the residence time of these particles over the base,
25 apart from those cases where the fibres are quite short. At greater lengths of the fibres these thus will have a tendency to wrap around the base material, which separates the holes in the base, and get stuck to the base, e.g. the threads, if the base consists of a net.
30 If the long fibres are forced to pass through otherwise too small holes, they can be torn to pieces and/or crumbled up. In this condition the fibres cannot contribute to increasing the strength of the product, and the product cannot obtain the intended quality.

The strength of the product depends to a great extent on the length of the fibres. If a high strength is wanted, the fibres must be long, and that requires sufficiently large holes in the base to enable the fibres to pass 5 without being damaged. It is, however, important that the materials obtain a sufficiently long residence time above the base, at the level of the rotor wings, to enable it to be distributed evenly and uniformly over the whole of this area, but this is not possible in the case of 10 comparatively small and heavy particles, as e.g. SAP, when the holes in the base are adapted for the passage of long fibres. In this case the particles, and any short fibres, will not be distributed evenly and uniformly over the entire area of the base, with the result that the 15 materials will not be mixed satisfactorily. The finished product such can contain accumulations with concentrations of short fibres and SAP particles, and these accumulations, which in the technical language are called nits, reduces the useful quality of the product as well 20 as its appearance and are therefore highly unwanted.

Danish lay open publication No. 162845 B disclose a plant for dry-forming a product of fibres only. In one of the two embodiments described, exists two fibre distributors 25 builded on top of each other. All fibres are added to the upper fibre distributor, wherein fibre lumps and tufts are separated from the material passing to the underlying fibre distributor as therefore can have comparatively large holes in the base and a correspondingly large 30 capacity. The top fibre distributor can have a similar large capacity, but as the holes of the base in this distributor must be small to prevent the fibre lumps and tufts to passing through, the large capacity are obtained in this case by means of a base with a considerably 35 larger area than the underlying fibre distributors base.

This construction could theoretically also be used for a composition of materials, which contains short fibres and e.g. SAP, whereby the upper fibre distributor will work in precisely the same manner as the plant known from said 5 Danish patent application No. 0265/93, therefore suffering from the same deficiencies and drawbacks as this plant regarding the ability to produce a product which has both a uniform and homogeneous structure and a very great strength. As it is the same material which has 10 to pass through both fibre distributors, an improvement of the degree of mixing in the upper distributor will not be obtained in the lower distributor, as this distributor only will repeat the mixing process having already taken place in the upper distributor.

15

A plant of the type mentioned in the opening paragraph is therefore needed for dry-producing a mainly thin web formed product, which has a more uniform structure and a greater relative strength than known before.

20

The novel and unique features according to the invention which enables this to be obtained consists in that the housing in the vertical direction is divided into distribution steps, each with a separate perforated base 25 and a set of rotors with wings, and that at least two of these distribution steps each are furnished with at least one independent inlet for materials.

By dividing the material distributor in this way into 30 independent distribution steps for each material, it now is possible to distribute and mix the respective materials over bases furnished with holes, which have just the size best fitted for the distribution and mixing process in the step in question. Materials which include 35 long fibres as well as particles and/or short fibres can therefore be used. The materials will be fed in the

order that they step by step downwards becomes larger/longer and lighter. The materials in an upper step already will be thoroughly distributed and mixed when these materials are falling down into the step beneath, 5 and finally all materials are distributed and mixed in the lower step, from where the resulting material mixture, via the base holes in this step, will fall down on the beneath running perforated forming belt in a now completely distributed and mixed condition, which is 10 kept completely in the finished product obtaining thereby an optimal even and uniform structure and optimised properties of great strength.

In the known plants the fresh materials are supplied over 15 one and the same base in the distributor, and after starting up and/or regulation, a stationary state of equilibrium is reached automatically, whereby the distributed and mixed materials are falling through the holes in the base in a single string material stream 20 concurrently with the new material falling down over the base.

According to the invention the material stream in the distributor is not, however, single stringed. The fresh 25 materials are supplied over several different bases each of which, apart from the upper one, receiving mixed material from the overlying step simultaneously. Several material streams can therefore be found in the distributor at the same time being not gathered or 30 becoming a single stream of material until over the lower base.

The total stream of materials into a step are thus made up of at least two streams, independent of each others, 35 namely at least one stream of fresh material and a stream of mixed material from the overlying step. The at least

two streams of materials are mixed in the step and the holes of the bases are therefore of such dimensions that the materials in a step pass through the holes in the base of this step concurrently with the materials in the 5 step beneath passing through the holes in the base of that step.

The fresh materials are normally included in quite different quantities in a product just as the physical 10 properties of those materials which at a given time are present in a step can vary very much step to step. The rotational speed of the rotors in the step concerned can therefore advantageously be determined in dependence on the demands of the specific material conditions in this 15 step, rather than letting the rotational speed be the same for all the sets of rotors concerned.

Moreover allowing the rotational speed to be adjustable, the step can in all cases be made to work at an optimum, 20 even if the step at different times is supplied with different amounts of materials, which at the same time also may have different physical properties.

The volume of the vertical stream of material through the 25 distributor increases in the direction of the stream concurrently with the stream being supplied with more fresh material step by step. In an expedient embodiment each distribution step can have the same or a smaller horizontal cross section than the distribution step 30 beneath, so that the stream of material can be allowed to spread unimpeded as it grows larger. If there isn't enough room in a step to fully carry out the distribution and mixing of the material in that step, it can lead to a deterioration of the degree of distribution as well as of 35 the degree of mixing.

The plant according to the invention is very suitable for the production of modern products such as nappies, sanitary towels and incontinence pads, all of which having both a content of SAP or SAF to absorb liquid, a
5 content of by way of example short cellulose fibres to make the product sufficiently cheap, and long fibres, in the form of by way of example thermo-binding fibres, e.g. bicomponent fibres, to give the product enough strength to enable it to be used, even if it is very thin.

10

In another expedient embodiment of the material distributor this can have three vertical distribution steps which each are feeded with one of these materials and in a succession where the upper step are feeded with
15 e.g. SAP, the intermediate step with e.g. cellulose fibres, and the lower step with long fibres, e.g. thermo-binding fibres.

In order to reduce the construction height of the
20 distributor the process can, however, also take place in a material distributor consisting of only two steps, as the upper step then can be feeded with both SAP and cellulose fibre.

25 A variation of the last mentioned embodiment can consist in dividing transversely by a partition the upper step into two sections, of which one are feeded with SAP and the other one with cellulose fibres. Each of these sections then advantageously can have a base with holes
30 fitting to the dimensions and physical properties, which SAP and cellulose fibres have respectively.

A common widely used method to produce a fibre product containing SAP fibres, consist of supplying the SAP
35 particles from an individual distributor whilst the fibres are supplied from two other distributors placed on

each side of the SAP distributor, along the forming belt. A laminated product is thereby produced, but as the product easily is splitted up in the layers it causes inconvenience for the consumers.

5

By this method in order to get the layers to stick together better, according to the invention, the intermediate distributor can be a material distributor with e.g. two steps. The upper one of these steps will
10 then be feeded with SAP, whilst fibres, which will bind the intermediate layer to the two outer layers from the other two distributors, will be feeded to the lower one of the steps.

15 The invention also concerns a process for dry-producing a web-formed product, by means of the plant according to the invention, by a composition of different materials, including fibres, and the novel and unique features of this process consist in that every distribution step is
20 feeded with a material having a greater rate of fall, in air, than the material feeded to the step beneath, whereby it is possible to effectively mix materials of very different dimensions, densities and physical properties and produce a homogenous, strong and thin
25 product.

The invention will be explained more fully below by stating further expedient properties and advantages of the plant according to the invention, and describing only
30 by way of examples some embodiments, with reference to the drawing, in which

Fig. 1 is a partially schematically view of a longitudinally section, seen from the side, of a first
35 embodiment for a plant according to the invention,

Fig. 2 shows the same taken at II - II in figure 1,

Fig. 3 shows the same taken at III- III in figure 2,

5 Fig. 4 is a partially schematically view of a longitudinally section, seen from the side, of a second embodiment for a plant according to the invention,

10 Fig. 5 is a partially schematically view of a longitudinally section, seen from the side, of a third embodiment for a plant according to the invention, and

15 Fig. 6 is a partially schematically view of a longitudinally section, seen from the side, of a fourth embodiment for a plant according to the invention.

Fig. 1 - 3 show a first embodiment for a plant according to the invention comprising a material distributor 1, a perforated forming belt(2) placed beneath the distributor, 20 and a suction unit 3 placed beneath the belt.

The material distributor is divided into three distribution steps in the vertically direction, namely an upper step 4, an intermediate step 5 and a lower step 6. 25 Each of these steps has a material inlet 7, 8 and 9, respectively, and a suction duct 10, 11 and 12, respectively. Each material inlet has a feeding duct 7', 8' and 9', respectively, connected to a wide mouthpiece 7", 8" and 9", respectively.

30

In fig. 2 the material inlet 7 of the upper step 4 can be seen, with its feeding duct 7' and its mouthpiece 7" extending across the distribution step 7 in order to distribute the supplied material over the total width of 35 the step. The other two material inlets 8 and 9 are in

fig. 2 hidden behind the material distributor 1, but are configured in the same way as the material inlet 7.

The material distributor 1 has a housing 13 with side walls 14 and a top wall 15. Each of the distributors steps 7, 8 and 9 are delimited downwards by a perforated base 16, 17 and 18, respectively, which can, by way of example, be a net.

10 In each of the steps 7, 8, and 9 there also can be found a set of rotors 19, 20 and 21, respectively. As best seen in fig. 3 showing a sectionally view through the lower step 6 taken at III - III in fig. 2, the set of rotors are divided into rows 22, which in the example shown 15 counts four in the lower step 6, three in the intermediate step 5, and two in the upper step 4.

Each set of rotors 19, 20 and 21 consists of a number of rotors 26 mounted for rotation in hollow bars, 22, 23 and 20 24, respectively, which extend from wall to wall across the housing 13. Via toothed belts 27 the rotors can be rotated by motors 28, 29 and 30, respectively, transmitting the power via gears 41, 42 and 43, respectively. The entire transmission is contained in the 25 hollow bars, thereby protecting the transmission from the materials falling down.

Each of the rotors 26 has a vertical shaft 31, each carrying at the bottom a rotor wing 32. As best seen in 30 fig. 3, the wings in each row alternately rotate at a phase shift of 90° in relation to each other, and all the rotors in a row rotate in the opposite direction of the rotors in the adjoining row or rows.

35 The row of rotors are furthermore displaced, in relation to each other, in the cross direction of the forming belt

in the way disclosed in the earlier mentioned Danish patent application no. 0265/93, "Apparatus for distribution of fibres", which are incorporated in the present application as reference. As can be seen, in this
5 example, the rotor in one row is aligned with a rotor in each of the other rows, and simultaneously the line of rotors forms an angle of e.g. 0° and 15° with the running direction of the forming belt. It is thereby possible to produce the web formed product with very small thickness
10 variations, which are demanded, if the product shall be very thin.

By using the known method from the above mentioned DK patent application in combination with the technique of
15 the present invention, a web formed product can now also be produced, which not only is thin with an even and uniform thickness, but also has a great strength and a homogeneous structure.

20 The suction unit 3 consists of a suction box 33 with an upper opening 34 placed closely under the forming belt 2, and a suction ventilator 35, which via a duct 36 is connected to the suction box 33.

25 When the plant is in operation, the ventilator 35 is working and sucking air from the housing 13 via the suction box 33 through the perforated forming belt 2, whereby an airstream is created in the direction of the arrows through the three feeding ducts 7', 8', 9' of the
30 housing 13 with associated mouthpieces 7", 8" and 9" and down through the three perforated bases or nets 16, 17 and 18 of the distributor steps.

A dry-produced product usually consists of several
35 different materials, which e.g., if the product is to be used for nappies, sanitary towels and incontinence pads,

may be SAP, short cellulose fibres and long thermo-binding fibres, e.g. bicomponent fibres.

The different materials are conveyed by the air streams
5 towards the perforated bases of the distributor steps,
and, with the above mentioned mixture of materials, the
small and heavy SAP particles will be led from the
material inlet 7 into the upper step 4, the some larger
and lighter cellulose fibres from the material inlet 8
10 into the intermediate step 5, and the long thermo-binding
fibres into the lower step 6.

The now rotating rotors will in each step cause the
materials to move, in a manner, which is in itself
15 already known, parallel along the rows of rotors across
the base of the step, whereby the materials are mixed and
distributed evenly over the area of this base. During
this the material will successively pass through the
holes of the base falling down into the step beneath or
20 down onto the forming belt in the case of the last step.

During this process some of the material in a step may be
collected or entangled in lumps or tufts, which are not
allowed to form part of the finished product or remain in
25 the step, where the lumps or tufts could form a hindrance
for the optimum operation of the process. The lumps or
tufts are therefore sucked out of the steps through the
suction ducts 10, 11 and 12.

30 Each of the holes in the bases of the steps are adapted
in size just to the material which is going to be mixed
and distributed in the step concerned.

In the upper step, to which the small and heavy SAP
35 particles are feeded, the holes are therefore relatively
small in order to prevent the particles to falling

through the holes too fast and the particles are thereby forcing the particles to remain so long in the step, that the particles can be distributed evenly over the total area of the base.

5

The cellulose fibres feeded to the intermediate step, are lighter than the SAP particles and have a greater extension, at least in the longitudinal direction. These fibres therefore demand larger holes in the base than the
10 SAP particles, but as these already are evenly distributed over a large area, when they meet the cellulose fibres in the intermediate step, the optimum distribution and mixture of the two materials is therefore already
15 materials, in a mixed condition are passing through the holes ... the base to the lower step.

The lower step must have even larger holes in its base on account of the long thermo-binding fibres, which are
20 feeded into this step, but, as the material coming from the intermediate step, is already evenly distributed and mixed, a perfect distribution and mixing of the materials will be obtained in the lower step as well, before the materials finally fall down onto the forming belt via the
25 base holes in the lower step.

On the forming belt, which runs continuously in the direction shown by the arrow, the materials will be forced, by the difference of the pressure over the
30 perforated forming belt, to lie in a tightly coherent layer, which are thereafter turned into the finished web formed product in a predetermined way, by going through a more specifically defined number of subsequent processes, depending on the desired properties of the product in
35 question, which e.g. with a content of long thermo-binding fibres can comprise a heat treatment,

where the thermo-binding fibres or similar materials are brought into a condition, by the heat, where the fibres are able to bind the materials of the product together to form a connected whole.

5

In this way a product can be produced from such different materials as SAP or SAF, short cellulose fibres and long thermo-binding fibres or bicomponent fibres, which has an extraordinarily even and uniform structure and at the
10 same time a very great strength, which makes it possible to produce thin and yet strong products.

The above mentioned mixture of materials should, however, only be seen as an example and the plant of the invention
15 can of course be used for many other materials and many different combinations of such materials.

The rotors may have wings and rotational speeds, which are adapted to just those materials, which are going to
20 be mixed and distributed in a step, and which can be of considerably different size and consistency. Moreover the rotational speeds can be variable so that a rotational speed can be chosen which best fit to the material, that is being treated in a step, at a particular time. The
25 plant can therefore easily be adjusted to suit any mixture of material.

As the materials successively are feeded in the vertical direction of the material distributor, the volume of the
30 stream of material through the distributor will increase step by step downwards, and the housing 13 shown in fig. 1 - 3 therefore accordingly is designed with a cross section which step-wise becomes correspondingly larger downwards, whereby the stream of material will have
35 enough room for the distribution and mixing of material, which must take place in each step. Another advantage is

that each step with, among other things, its content of rotors does not get larger and thereby more expensive than strictly necessary in order to be able to treat just the amount of material fed to that step. Instead of
5 the shown graduation of the side walls 14 of the housing 13 these walls can be plane walls, which diverge in a downward direction (not shown).

Fig. 4 - 6 show three other embodiments for a material
10 distributor according to the invention. These embodiments are constructed, and work, on the same principle as the first embodiment shown in fig. 1 - 3, and the description of the fundamental functions of the plant will therefore not be repeated in every single case. In the following
15 the description will be concentrated only on the specific properties and advantages of these further embodiments. The same reference numbers for identical parts are used in all cases.

20 Fig. 4 shows the second embodiment where the upper and intermediate steps have now been combined to a single step 4, 5, which has both a material inlet 7 for e.g. SAP, and a material inlet 8 for e.g. short cellulose fibres. These materials allow themselves to be
25 distributed and mixed in the same step with reasonably good results, and the lower step 6 will then be fed, as in the first embodiment, with long fibres in the form of e.g. thermo-binding fibres. The advantage of this version is first and foremost that it provide a reducing
30 of the overall height, and that the plant will be cheaper to build.

Fig. 5 shows the third embodiment, which is a variation of the second embodiment shown in fig. 4, as there are,
35 also in this case, just two steps, an upper step 4, 5 and a lower step 6. The specific difference to the second

embodiment is that the upper step 4, 5 with a transverse partition 37 now are divided into two separate chambers 4 and 5, each being feeded with a specific material, e.g. SAP and cellulose fibres, respectively, and each having their own material inlet 7 and 8, respectively. Furthermore, each chamber has now been furnished with bottom holes, which has a size being adapted to just the material feeded into the chamber in question.

10 The third embodiment has, like the second embodiment, the advantage that there is provided a reducing of the overall height, and at the same time the plant will be cheaper to build. Moreover there is obtained the considerable additional advantage that the two materials
15 supplied to the upper step, now can be distributed independently of each other and therefore better, because the distribution takes place in each individual chamber, each with its own type of holes in the base.

20 Fig. 6 shows the fourth embodiment, which comprises three separate material distributors 38, 39 and 40 placed in a row along the forming belt 2. In the case shown the two outer distributors 38 and 40 in the row only have one step each and can, in itself, consequently be conventional material distributors. The intermediate distributor 39 is however, a material distributor according to
25 the invention with two steps.

This embodiment can advantageously be used to produce a
30 laminated product in the following way.

The first distributor 38 is used to place an initial layer of fibre, e.g. long thermo-binding fibres on the forming belt 2. The intermediate distributor 39 is
35 thereafter used to place a mixed intermediate layer of for example SAP and fibres, e.g. cellulose fibre on top

of the initial layer, as SAP is feeded to the upper step 4 and the fibres to the lower step 6. Finally the last distributor 40 is used to place a final layer of fibres, e.g. thermo-binding fibres as well, on top of the 5 intermediate layer. A laminate is thereby created with a intermediate layer which contains fibres and therefore sticks together far better with the outer layers than conventional laminates, which are produced by means of three distributors, but where only SAP or a similar 10 material is feeded to the intermediate distributor.

The described method for production of laminates with great coherent strength can, of course, be varied in many ways. Thus the two outer distributors 38 and 40 also may 15 be equipped with two or more steps for the creation of layers, which consist of more than just one material, and the intermediate step may have more than two steps, so that the intermediate layer possibly can contain more than just two different materials. Laminates thus can be 20 produced in any desired composition.

It should be recognised that the above described and in the drawing shown different embodiments for a plant according to the invention only serve to exemplify the 25 invention, as many other embodiments are conceivable within the scope of the invention.

Thus a material distributor can have more than three steps which, however, must all be organised so that every 30 step is feeded with a material, which has a greater rate of fall, in air, than the material which is supplied to the step beneath.

Neither is it necessary for the housing to have a cross 35 section enlarging step by step downwards. The housing can also have plane vertical side walls and equally large

cross section on all horizontal levels, or even side walls which converge planely or stepwise downwards.

Furthermore, the set of rotors in each step can consist 5 of the same number of rotors, and in these set of rotors, one rotor in each step can have a common shaft, and one row of rotors in each step can have a common driving motor.

10

15

20

25

30

35

P a t e n t C l a i m s :

1. A plant for producing, under dry conditions, a web
5 formed product by compounding different materials,
including fibres, whereby the plant comprises an endless,
during operation mainly horizontal running perforated
forming belt, a beneath the belt placed suction unit, and
at least one above the belt placed material distributor
10 with a housing having side walls and a lower perforated
base, material inlets for the different materials in the
compound, and a set of rotors with wings rotating during
operation to mix the materials and distribute these over
the base, c h a r a c t e r i z e d in that the housing
15 in the vertical direction is divided into distribution
steps, each with a separate perforated base and a set of
rotors with wings, and that at least two of these
distribution steps each are furnished with at least one
independent inlet for materials.

20

2. A plant according to claim 1, c h a r a c t e r i z e
d in that the holes in the perforated bases are of such a
size, that the materials in one step will pass through
the holes of the base concurrently with the materials in
25 the underlying step passing through the holes of the base
of that step.

3. A plant according to claim 1 or 2, c h a r a c t e r i
z e d in that the rotors in at least one of the set of
30 rotors, associated with the distribution steps, has a
rotational speed, which differs from the rotational
speeds of the rotors of the remaining set of rotors.

35 4. A plant according to claim 1, 2 or 3, c h a r a c t e
r i z e d in that the rotors in at least one of the set

of rotors, associated with the distribution steps, has an adjustable rotational speed

5. A plant according to one or more of the claims 1 - 4, characterized in that every distribution step has the same or a smaller horizontal cross section than the underlying distribution step.

6. A plant according to one or more of the claims 1 - 5, characterized in that it comprises an upper, first distribution step for at least one liquid-absorbing agent and a lower, last distribution step for fibres, the length of which are mainly greater than about 2.5 mm.

7. A plant according to one or more of the claims 1 - 6, characterized in that at least one of the distribution steps has two or more material inlets.

8. A plant according to one or more of the claims 1 - 7, characterized in that at least one of the distribution steps placed above the lower distribution step has two or more material inlets, each for separate materials, that these material inlets are connected to the distribution step spaced apart in the longitudinal direction of the forming belt, that the distribution step with transverse partitions between the individual connections has been divided into sections, and that the perforated holes of the base of each section are of such a size, that the materials in one section pass through the holes in the base of this concurrently with the materials in the underlying step passing through the holes in the base in this step.

9. A plant according to one or more of the claims 1 - 8, characterized in that it comprises a first material distributor and at least one subsequent material

distributor, placed in the running direction of the belt, comprising an upper, first distribution step for at least one liquid-absorbing agent and a lower, last distribution step for fibres.

5

10. A process for dry-producing a web-formed product, by a composition of different materials, including fibres, by means of a plant for producing, under dry conditions, a web formed product by compounding different materials, including fibres, whereby the plant comprises an endless, during operation mainly horizontal running perforated forming belt, a beneath the belt placed suction unit, and at least one above the belt placed material distributor with a housing having side walls and a lower perforated base, material inlets for the different materials in the compound, and a set of rotors with wings rotating during operation to mix the materials and distribute these over the base, whereby the housing in the vertical direction is divided into distribution steps, each with a separate perforated base and a set of rotors with wings, and at least two of these distribution steps are furnished with an independent inlet for materials, characterized in that every distribution step is feeded with a material having a greater rate of fall, in air, than the material feeded to the step beneath.

11. A process according to claim 9, characterized in that the first distribution step is feeded with a liquid-absorbing agent and the last distribution step with fibres, the length of which are mainly greater than about 2.5 mm.

12. A process according to claim 9 or 10 with two distribution steps, characterized in that the first step is feeded with at least one liquid-absorbing agent and fibres of a length up to about 2.5 mm, e.g.

cellulose fibres, and the second step with fibres of a length greater than about 2.5 mm, e.g. thermo-binding fibres.

5 13. A process according to claim 9 or 10 with three
distribution steps, c h a r a c t e r i z e d in that the
first step is feeded with a liquid-absorbing agent, the
second step with fibres of a length up to about 2.5 mm,
e.g. cellulose fibres, and the third step with fibres of
10 a length greater than 2.5 mm, e.g. thermo-binding fibres.

15

20

25

30

35

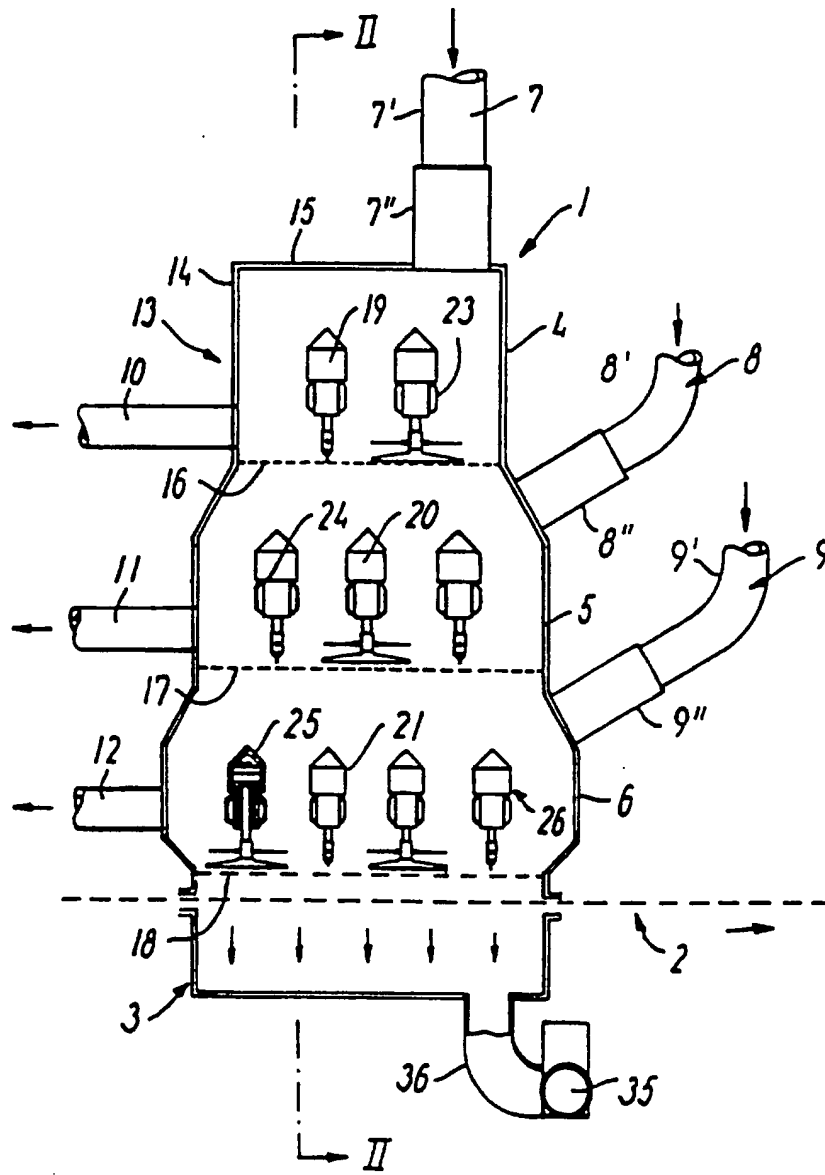

FIG. 1

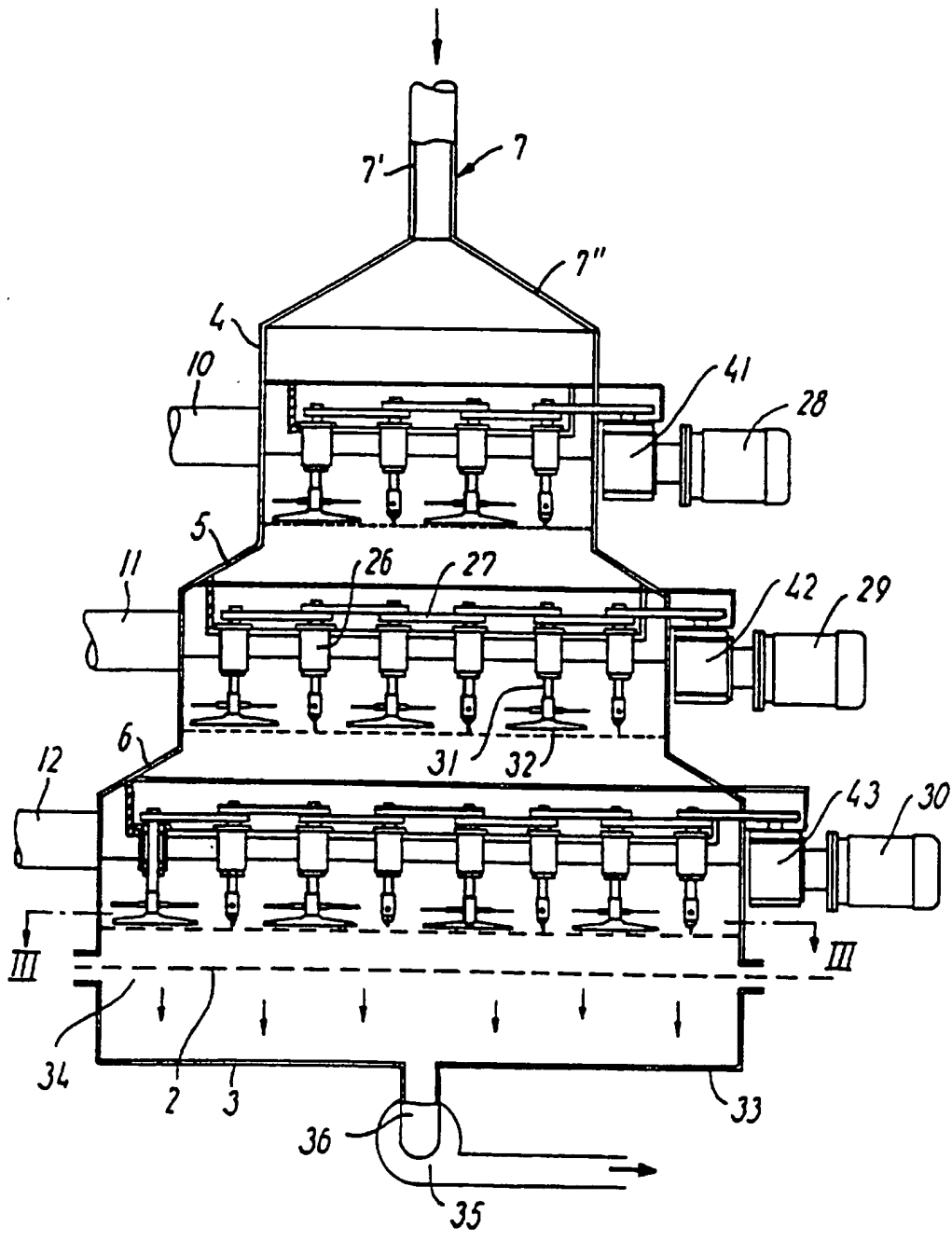

FIG. 2

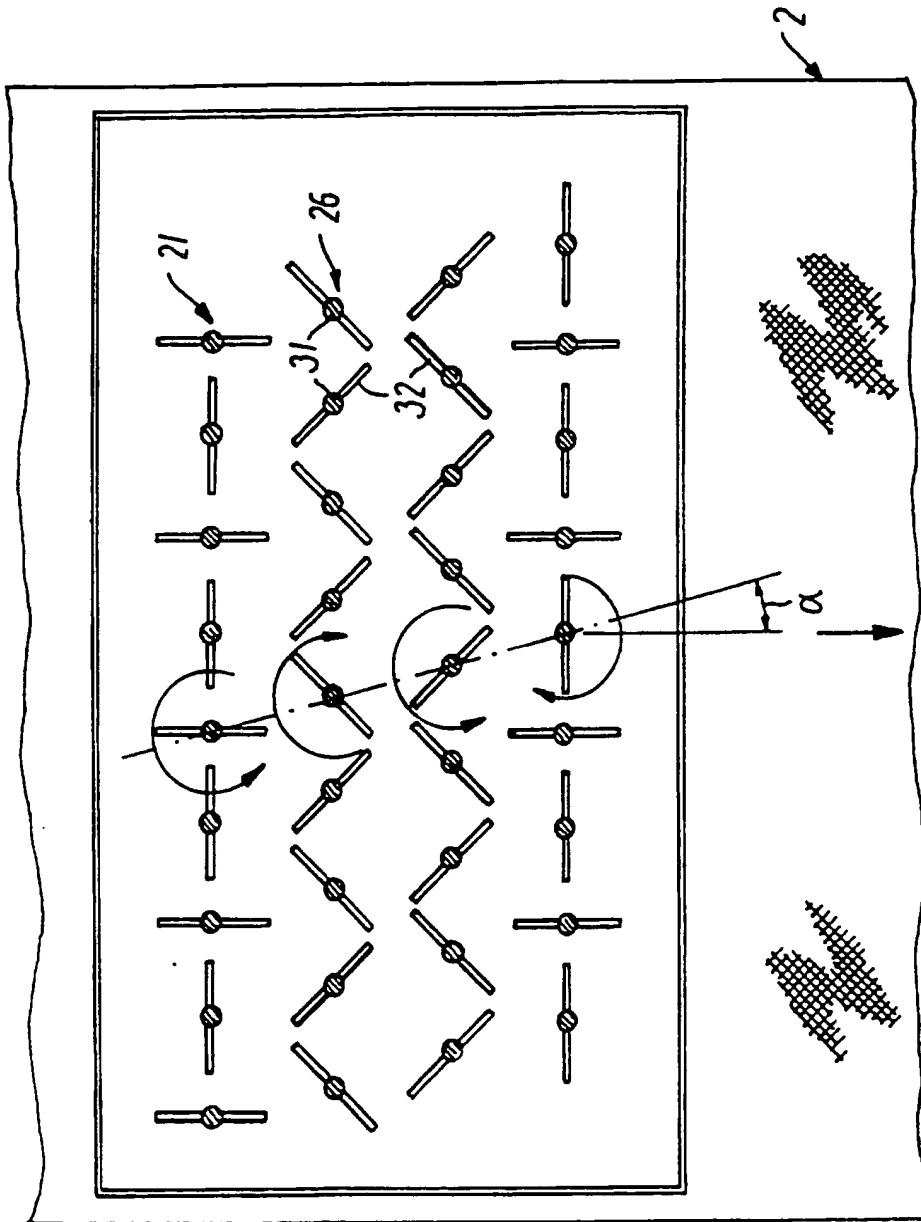

FIG. 3

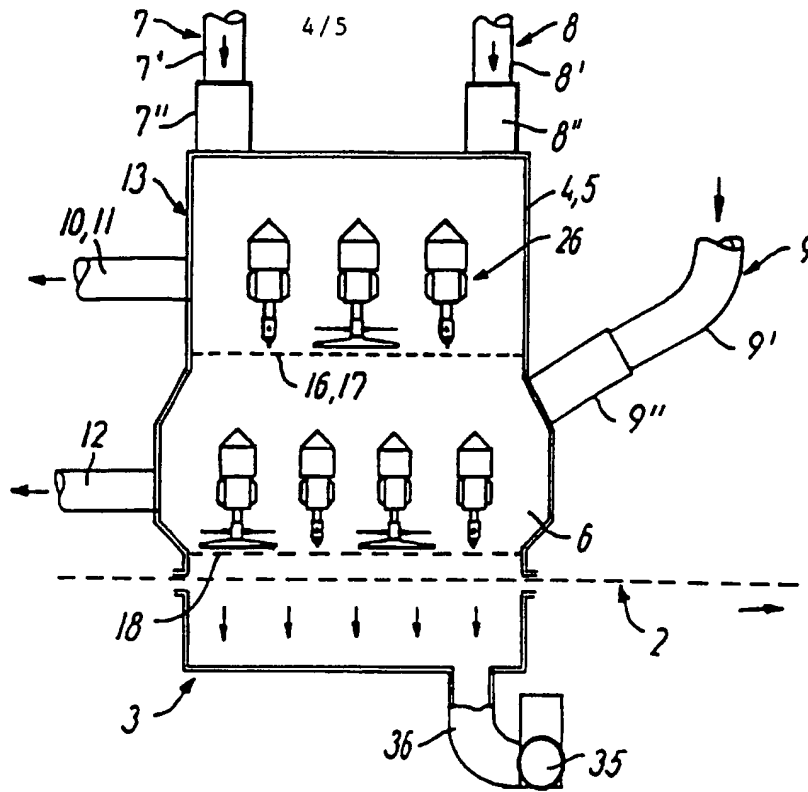

FIG. 4

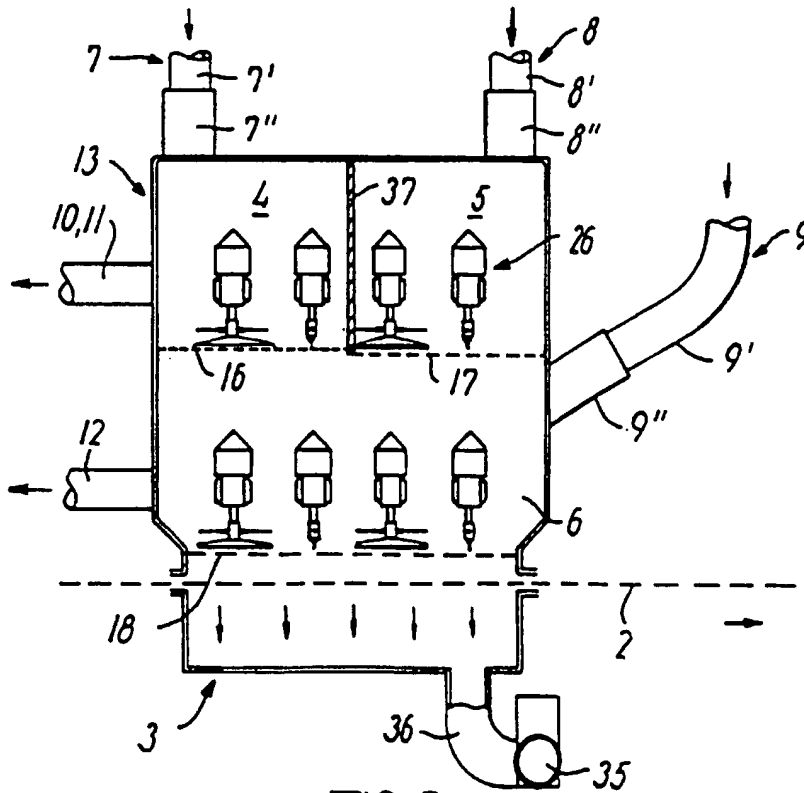

FIG. 5

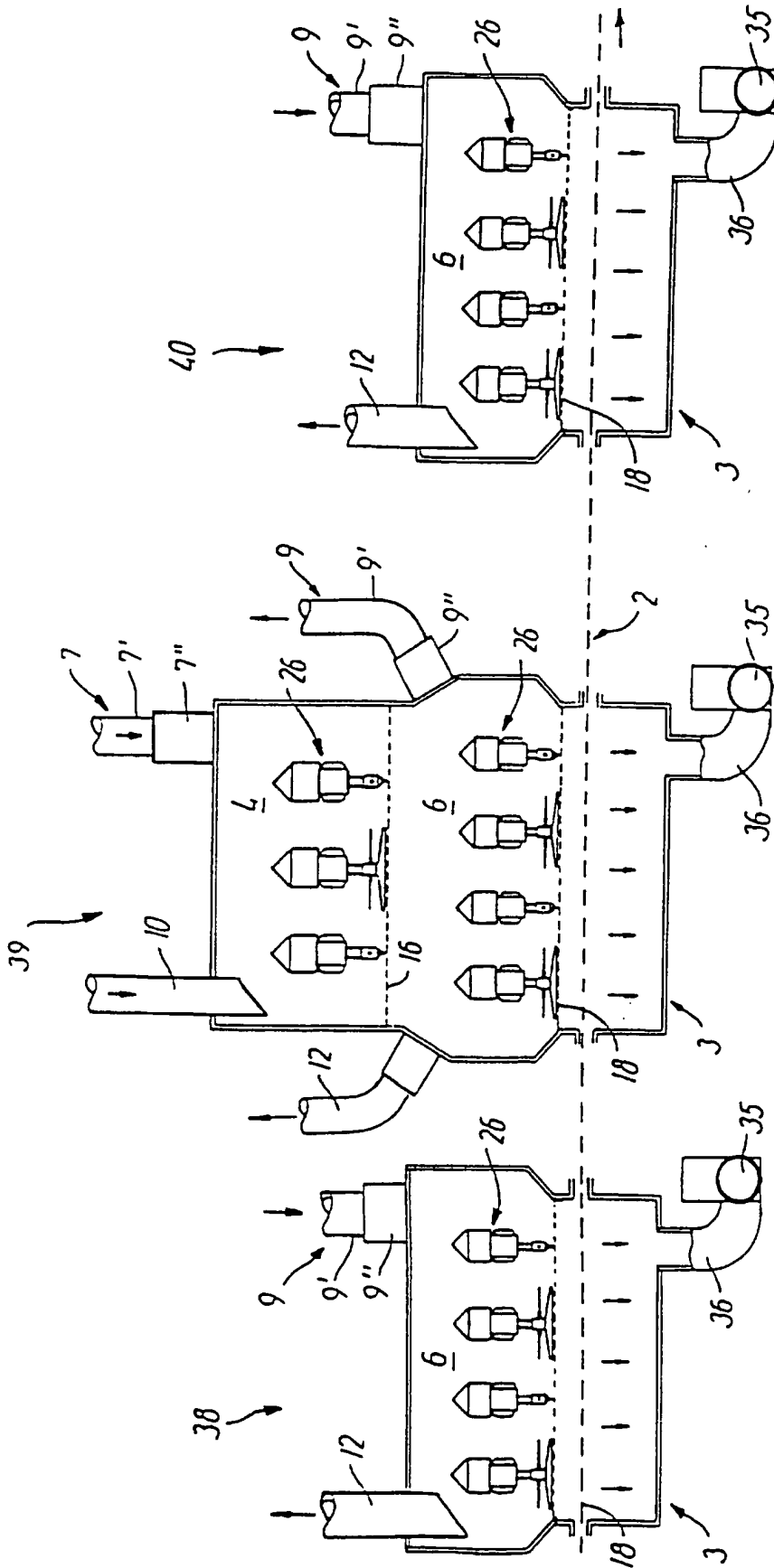

FIG. 6

INTERNATIONAL SEARCH REPORT

International application No.

PCT/DK 95/00359

A. CLASSIFICATION OF SUBJECT MATTER

IPC6: D01G 25/00, D04H 1/72 // D21H 27/00

According to International Patent Classification (IPC) or to both national classification and IPC

B. FIELDS SEARCHED

Minimum documentation searched (classification system followed by classification symbols)

IPC6: D21H, D01G, D04H, A61F

Documentation searched other than minimum documentation to the extent that such documents are included in the fields searched

SE,DK,FI,NO classes as above

Electronic data base consulted during the international search (name of data base and, where practicable, search terms used)

WPI, CLAIMS

C. DOCUMENTS CONSIDERED TO BE RELEVANT

Category*	Citation of document, with indication, where appropriate, of the relevant passages	Relevant to claim No.
A	WO 9105100 A1 (KROYER, K.K.K.), 18 April 1991 (18.04.91), figures 3-6, claims 1-3 --	1-13
A	EP 0006326 A1 (AMERICAN CAN COMPANY), 9 January 1980 (09.01.80), figure 2, abstract -----	1-13

 Further documents are listed in the continuation of Box C. See patent family annex.

* Special categories of cited documents:

- *A* document defining the general state of the art which is not considered to be of particular relevance
- *E* earlier document but published on or after the international filing date
- *L* document which may throw doubts on priority claim(s) or which is cited to establish the publication date of another citation or other special reason (as specified)
- *O* document referring to an oral disclosure, use, exhibition or other means
- *P* document published prior to the international filing date but later than the priority date claimed

T later document published after the international filing date or priority date and not in conflict with the application but cited to understand the principle or theory underlying the invention

X document of particular relevance: the claimed invention cannot be considered novel or cannot be considered to involve an inventive step when the document is taken alone

Y document of particular relevance: the claimed invention cannot be considered to involve an inventive step when the document is combined with one or more other such documents, such combination being obvious to a person skilled in the art

Z document member of the same patent family

Date of the actual completion of the international search

Date of mailing of the international search report

7 December 1995

15 -01- 1996

Name and mailing address of the ISA/
Swedish Patent Office
Box 5055, S-102 42 STOCKHOLM
Facsimile No. +46 8 666 02 86

Authorized officer

Barbro Nilsson
Telephone No. +46 8 782 25 00

INTERNATIONAL SEARCH REPORT
 Information on patent family members

30/10/95

International application No.

PCT/DK 95/00359

Patent document cited in search report	Publication date	Patent family member(s)	Publication date
WO-A1- 9105100	18/04/91	NONE	
EP-A1- 0006326	09/01/80	SE-T3- 0006326	
		AT-E,T- 9237	15/09/84
		CA-A- 1112833	24/11/81
		JP-C- 1445384	30/06/88
		JP-A- 55012895	29/01/80
		JP-B- 62053623	11/11/87
		US-A- 4180378	25/12/79

**This Page is Inserted by IFW Indexing and Scanning
Operations and is not part of the Official Record**

BEST AVAILABLE IMAGES

Defective images within this document are accurate representations of the original documents submitted by the applicant.

Defects in the images include but are not limited to the items checked:

- BLACK BORDERS
- IMAGE CUT OFF AT TOP, BOTTOM OR SIDES
- FADED TEXT OR DRAWING
- BLURRED OR ILLEGIBLE TEXT OR DRAWING
- SKEWED/SLANTED IMAGES
- COLOR OR BLACK AND WHITE PHOTOGRAPHS
- GRAY SCALE DOCUMENTS
- LINES OR MARKS ON ORIGINAL DOCUMENT
- REFERENCE(S) OR EXHIBIT(S) SUBMITTED ARE POOR QUALITY
- OTHER: _____

IMAGES ARE BEST AVAILABLE COPY.

As rescanning these documents will not correct the image problems checked, please do not report these problems to the IFW Image Problem Mailbox.